

Jergens[®]



BALL LOCK[™] MOUNTING

SYSTEMS

Shanks

Fixture Plates

Subplates

Pre-Engineered
Ball Lock Kits

Multi-Purpose
Subplates

Lite Lock
Mounting System

Accessories

Ball Lock[™]
Mounting
System

 Made in
USA
Proudly Manufactured in
Cleveland, OH



Quality System Certified



The Ball Lock Mounting System is used as a Quick Change Solution on the following:

- CNC Machines
- Palletized Fixtures
- Stamping
- Fabricating
- Injection Molding
- Packaging Machines
- Assembly Machines
- EDM
- Robotics
- Welding Fixtures

Fixture Plates	9
Fixture Plates for Multi-Purpose Subplate	7
Fixture Plates for Tooling Columns	12
Liners	5
Lite Lock Mounting System	18-19
Multi-Purpose Subplate	6
Quick Change Kits	13
Receiver Bushings	5
Repair Kits	4
Shanks	4
Subplates	8
Subplates for Tooling Columns	12
T-Columns	10
4-Sided Tooling Columns	11
Pre-Engineered Ball Lock Kits	14
Rotary Indexers	15
Accessories	17

Lean Manufacturing and Set Up Reduction Applications

Accurately Locate and *Lock Fixture* Plates to Subplates in Seconds...



00:60

Machining Cast Part

Previous Set Up Method: Located part with dowel pins, bolted part to tombstone fixture. Indicated part to zero datum point.

Previous Set-Up Time: 15 minutes

Set Up Using Ball Lock System: Mount parts to fixture plate while machining other parts. Mount fixture plate to tombstone using Ball Lock shanks. No indicating required because system provides $\pm .0005$ repeatability.

Set Up Time With Ball Lock System: 60 seconds

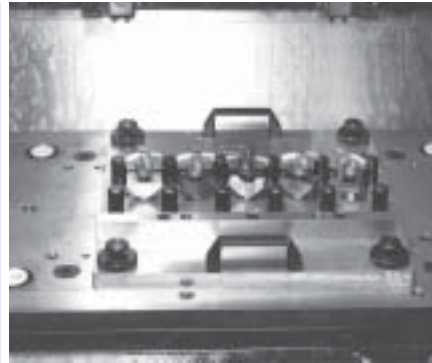

00:60

CNC Machine Base:

Drilling and reaming forged part.

Previous Set Up Method: Fixture plate located with dowel pins bolted to machine base. Fixture plate and parts indicated.

Previous Set Up Time: 7 minutes

Set Up Using Ball Lock System: Parts are pre-mounted on fixture plate, which is then mounted to machine base using Ball Lock shanks. No need to indicate.

Set Up Time with Ball Lock System: 60 seconds



01:20

CNC Vertical Machining Center

Machining aircraft valve parts

Previous Set Up Method: New Project. New Machine. No Prior History.

Previous Set Up Time: New Set Up.

Set Up Using Ball Lock System: Using Ball Lock Jig Saw Plate on Multi-Purpose Subplate enables operator to mount two more vises on the fixture. No indicating needed.

Set Up Time With Ball Lock System: 80 seconds setting up six vises.

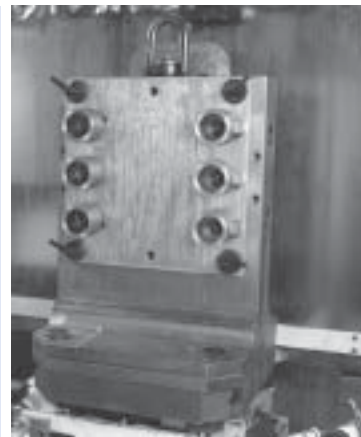

00:45

Two-Sided Tombstone:

Drilling and tapping cylindrical bodies.

Previous Set Up Method: Fixture located and bolted to tombstone. Had to be indicated.

Previous Set Up Time: 12 minutes

Set Up Using Ball Lock System: Fixture plate mounted and located with Ball Lock shanks. No need to indicate.

Set Up Time with Ball Lock System: 45 seconds

...With No Indicating Required



Locates

The Ball Lock™ System accurately positions your workpiece...to within $\pm .0005''$ repeatability, minimizing the need to indicate your fixture.



Locks

The Ball Lock System securely holds fixture plates to subplates with up to 20,000 lbs. of hold-down force per shank.

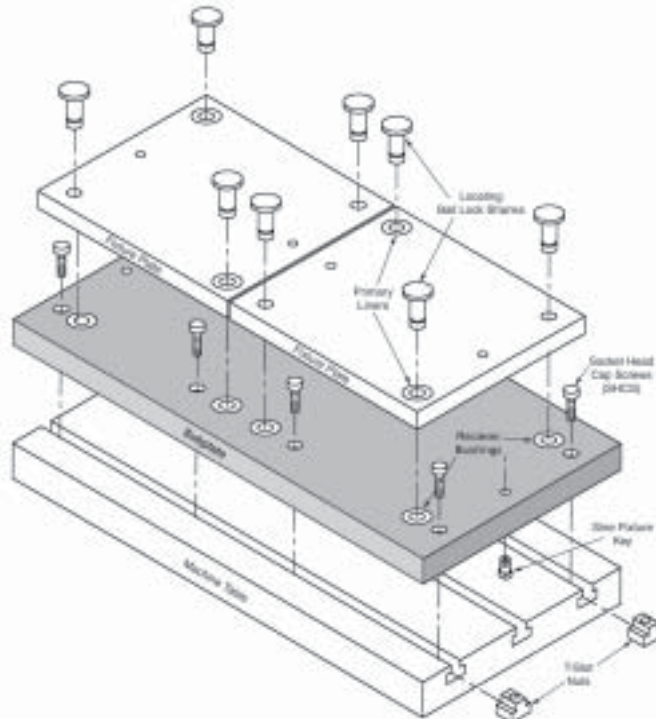

The Ball Lock Mounting System is designed to speed accurate locating and locking of fixture plates and subplates. The system consists of three parts: a Locating Shank, a Liner Bushing, and a Receiver Bushing. Using the Ball Lock Mounting System is a simple three step process. Install receiver bushings in your machine table or subplate,

and liner bushings in your fixture plate; then insert the locating shanks through the liners and into the receivers to provide accurate location. A couple of turns of the set screw in each of the locating shanks provides positive holding force. Eighteen locating shanks, two types of receiver bushings, and two types of liner bushings are available to

suit your individual requirements. It is recommended that the use of the Ball Lock Mounting System for locating and clamping of fixture plates be incorporated in a systematic process. All fixture plates should have two locating points positioned as far apart as possible. There is no advantage to

Most Commonly Asked Questions

Q. What is the Ball Lock System?

A. A means of locating and locking two flat surfaces together. These are usually a fixture plate and a subplate.

Q. How does it locate the plate?

A. It locates in the same manner as locating pins. In other words, there are two precision bores (receiver bushings) located on two precision pins (shanks).

Q. How many shanks (pins) do I need to locate the plate or part?

A. Two shanks are the maximum needed to locate. Anything more is a hindrance rather than a help. (This also applies to locating pins.)

Q. How does it lock?

A. The Ball Lock system achieves its holding force by a combination of force generators. A threaded screw exerts force onto a center ball which, in turn, directs this force onto three balls that register on a taper seat.

Q. How many do I need to lock the part?

A. This would depend on the particular application, but in most cases, we would recommend that at least four shanks be used (two shanks to locate and lock, and two shanks to lock only).

Q. If I should only locate on two shanks, how do I install the other two shanks without causing interference?

A. This is accomplished by only using liner bushings for the locating shanks and drilling a clearance hole (shank diameter plus approximately .030") for the remaining shanks.

Q. How close a repeatability can I expect?

A. If the center distance between the two locating holes (receiver bushings) is held to $\pm .0002''$ tolerance, and two primary liner bushings are used, then repeatability of $\pm .0005''$ can be maintained.

Q. What is the difference between the primary and the secondary liner bushings?

A. The only difference between the primary and the secondary liner bushings is that the secondary liner

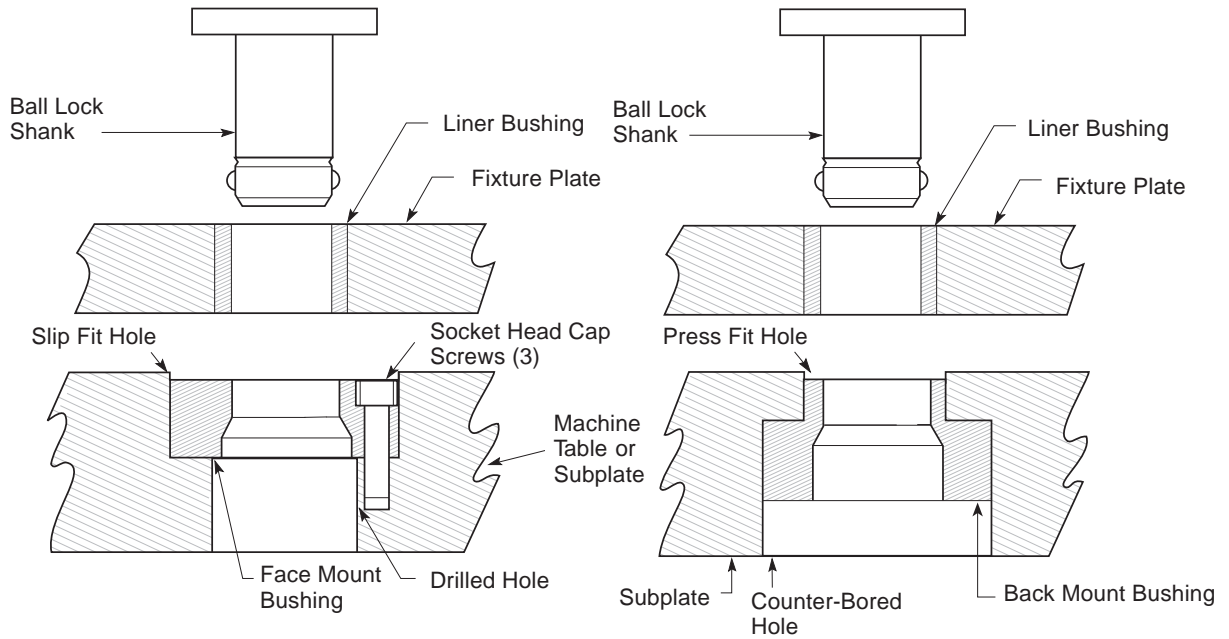

Mounting Method With Face Mount Bushing

Mounting Method With Back Mount Bushing

having more than two locating points. If more than two flanged shanks are required to provide additional hold-down force, omit liner bushings in the additional holes in the fixture plate and allow .030 over the nominal size. The additional clearance will insure that these holes have no influence on the locating holes.

How Accurate Does Your Positioning Have to Be?

The center distance of the receiver bushings in the machine table, tombstone, or subplate should be as accurate as possible ($\pm .0002$ recommended). Accurate location will insure a sound base for interchangeability of numerous fixture plates. For accurate repeatability within .0005 of true position,

both of the liner bushings in the fixture plate should be *primary* liners and the center distance tolerance should be $\pm .0002$. For slightly less accurate repeatability (within .0015 of true position), use one *primary* and one *secondary* liner with a center distance tolerance of $\pm .001$.

bushing has an oversized I.D. to accommodate the wider center distance tolerance on your fixture.

Q. Is there a preferable location for the liner bushing?

A. The location of the liner bushing is not critical, but in order to be consistent, we recommend that wherever possible, locate the liner bushings at bottom left and at top right.

Q. What are the advantages of using the Ball Lock System over the conventional method of dowel pins and cap screws?

A. Both locating and locking are accomplished in the same motion. Two and one half turns are the maximum needed to

lock (whereas a 1/2–13 cap screw with one and a half diameters of thread engagement would need ten turns to lock). On CNC machines, the repeatability of fixture locations makes indicating of the fixture unnecessary.

Q. If I need to recess the fixture plate in order to have a clear surface, what do I have to do?

A. Counterbore the fixture plate to a diameter large enough to allow easy removal of the shank. Note: The thickness of the plate section under the head of the shank is critical! It must conform to plate thickness recommended in the catalog.

Q. What if my plate is thinner than the recommended thickness?

A. It is possible that by adjusting the depth of the counterbore for the receiver bushing, you can still use the Ball Lock System. If there are any questions on this type of application, please call 1-800-JERGENS.

Q. Can I use the shanks in a heated environment?

A. The shank is made of alloy steel, heat treated to 40-45Rc and should stand temperatures up to 400°F. However, the "O" Ring that retains the balls could disintegrate.

Note: Be aware that thermal expansion of your plate could affect the center distance tolerance and repeatability.

Shanks and Repair Kits



- Material: Shank/Bushing, 4340
Liner, 52100
- Finish: Black Oxide
- Heat Treat: Shanks, RC 40-45
Bushings, RC 50-54
Liners, RC 62-64

Available for High Temperature Applications

- Stainless Steel available in all sizes

U.S. Patent No's. 3,498,653
4,135,418

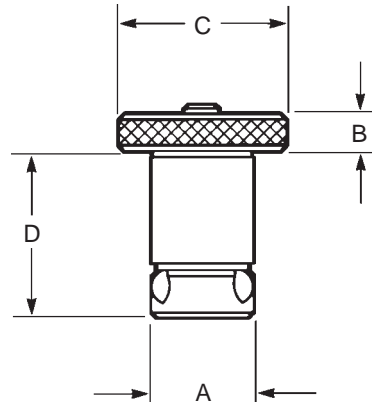

Ball Lock Repair Kits



- Each Kit Includes:
- Replacement Screw
 - Locking Balls
 - Drive Ball
 - O-Ring

Any Ball Lock application requires at least two sets of shanks, receiver bushings and liners. The liners are placed into the fixture plate to insure extremely accurate positioning. If more than two shanks are required (to provide additional hold down force), omit the liner bushing so that these additional holes will not interfere with your primary locating holes.

See page 1.19 for additional Shank styles and options.

Locating Shank Dimensions

Fixture Plate Thickness ±.005	Shank Part Number	Shank Diameter (mm) A	B	C	D	Maximum Holddown Force (lbs)	Recommended Screw Torque (Ft/lb)	Hex Wrench Size For Set Screw	Repair Kit Part Number
.50	49605	13	.25	.87	1.08	750	1	3/32	49905
.75	49606	13	.25	.87	1.33	750	1	3/32	49906
.50	49607	16	.32	1.50	1.15	1,200	2	1/8	49907
.75	49608	16	.32	1.50	1.40	1,200	2	1/8	49908
.75	49601	20	.38	1.75	1.53	3,000	3	1/8	49901
1.00	49602	20	.38	1.75	1.78	3,000	3	1/8	49902
.75	49611	25	.38	2.00	1.70	7,000	7	5/32	49911
1.00	49612	25	.38	2.00	1.95	7,000	7	5/32	49912
.75	49621	30	.50	2.25	1.88	10,000	12	3/16	49921
1.00	49622	30	.50	2.25	2.13	10,000	12	3/16	49922
.75	49631	35	.50	2.25	1.97	15,500	19	1/4	49931
1.00	49632	35	.50	2.25	2.22	15,500	19	1/4	49932
1.50	49633	35	.50	2.25	2.72	15,500	19	1/4	49933
2.00	49634	35	.50	2.25	3.22	15,500	19	1/4	49934
.75	49641	50	.75	3.00	2.45	20,000	38	3/8	49941
1.00	49642	50	.75	3.00	2.70	20,000	38	3/8	49942
1.50	49643	50	.75	3.00	3.20	20,000	38	3/8	49943
2.00	49644	50	.75	3.00	3.70	20,000	38	3/8	49944

Receiver Bushings



Back Mount



Face Mount

Two styles of receiver bushings are available. Generally, the face mount receiver bushing is utilized in blind hole applications (Slip Fit). The back mount receiver bushing is used in through hole applications (Light Press Fit).

Note: Installed bushings should be approximately .012" below subplate surface.

See reference below for installation of back mount style bushings.

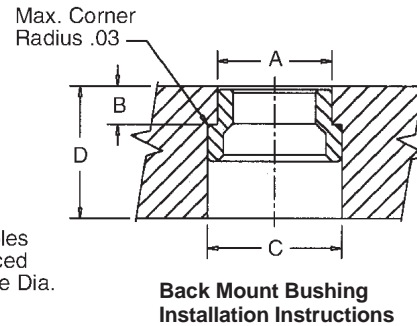
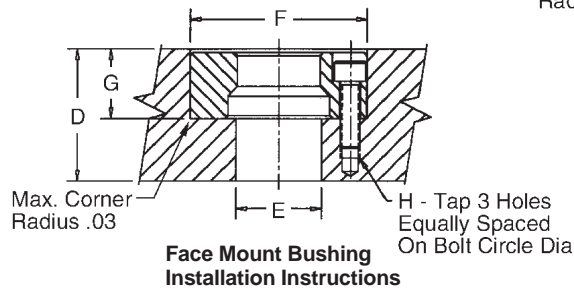

Installation Dimensions

Face Mount

Shank Dia. (mm)	Face Mount Part Number	Actual O.D. +.0000 - .0004	Clearance Drill Diameter E	Bore +.0005 - .0000 F	Depth +.002 - .000 G	Tap Size & Depth ¹ H	Bolt Circle Diameter 3 PL Equally Spaced	Min. Subplate Thickness D
13	49506	1.3750	11/16	1.3750	0.469	8-32x5/16	0.984	3/4
16	49507	1.4370	13/16	1.4370	0.469	8-32x5/16	1.125	3/4
20	49501	1.6873	13/16	1.6873	0.637	10-32x3/8	1.362	1
25	49502	2.0623	1	2.0623	0.799	1/4-28x1/2	1.644	1-1/4
30	49503	2.2654	1 3/16	2.2654	0.871	1/4-28x3/4	1.876	1-3/8
35	49504	2.6873	1 9/16	2.6873	0.904	5/16-24x7/8	2.178	1-1/2
50	49505	3.4998	2 5/32	3.4998	1.239	3/8-24x1	2.916	2

Back Mount

Shank Dia. (mm)	Back Mount Part Number	Actual O.D. +.0000 - .0004 A	Depth +.000 - .002 B	C-Bore ±.006 C	Min. Subplate Thickness D
13	49516	0.7870	.277	1.000	3/4
16	49517	0.8760	.285	1.155	3/4
20	49511	1.0950	.345	1.280	7/8
25	49512	1.3763	.416	1.593	1
30	49513	1.6264	.432	1.906	1-1/4
35	49514	1.8764	.493	2.155	1-5/16
50	49515	2.6269	.621	2.988	1-3/4

¹Cap Screws Supplied with Face Mount Bushings.

Liners



Locating repeatability will determine if one primary and one secondary or two primary liners are needed. With two primary liners, repeatability of ±.0005" can be maintained if the two holes for receiver bushings are held to a centerline distance of ±.0002" tolerance.

Note on Installation of Back Mount Style:

To alleviate the possibility of binding the shank in the bore, the maximum interference fit between bore and bushing O.D. should not exceed .0005".

Liner Dimensions

Fixture Plate Thickness ±.005	Shank Diameter (mm)	Primary Liner Part Number	Secondary Liner Part Number	Liner O.D. +.0000 - .0004
.50	13	49705	49805	0.7518
.75	13	49706	49806	0.7518
.50	16	49707	49807	1.0018
.75	16	49708	49808	1.0018
.75	20	49701	49801	1.3772
1.00	20	49702	49802	1.3772
.75	25	49711	49811	1.3772
1.00	25	49712	49812	1.3772
.75	30	49721	49821	1.7523

Fixture Plate Thickness ±.005	Shank Diameter (mm)	Primary Liner Part Number	Secondary Liner Part Number	Liner O.D. +.0000 - .0004
1.00	30	49722	49822	1.7523
.75	35	49731	49831	1.7523
1.00	35	49732	49832	1.7523
1.50	35	49733	49833	1.7523
2.00	35	49734	49834	1.7523
.75	50	49741	49841	2.5025
1.00	50	49742	49842	2.5025
1.50	50	49743	49843	2.5025
2.00	50	49744	49844	2.5025

Multi-Purpose Subplates

The Jergens Multi-Purpose Subplate is ideal for adapting your machine tools to accommodate most fixtures. Its versatility, coupled with the quick change capabilities of the Ball Lock Mounting System, makes it ideal for any size production run.

- Material: FreMax™ 15 Steel or Equivalent
- Thickness: 1 1/4"
- Thickness Tolerance: ± .005
- Weight: 285 Lbs.
- Subplate will accept combinations of six different standard Ball Lock Fixture Plates
- Includes installed Ball Lock Receiver Bushings
- Ideal solution to increase production
- Made in U.S.A.

20x40 Multi-Purpose Subplate

Part Number
49112

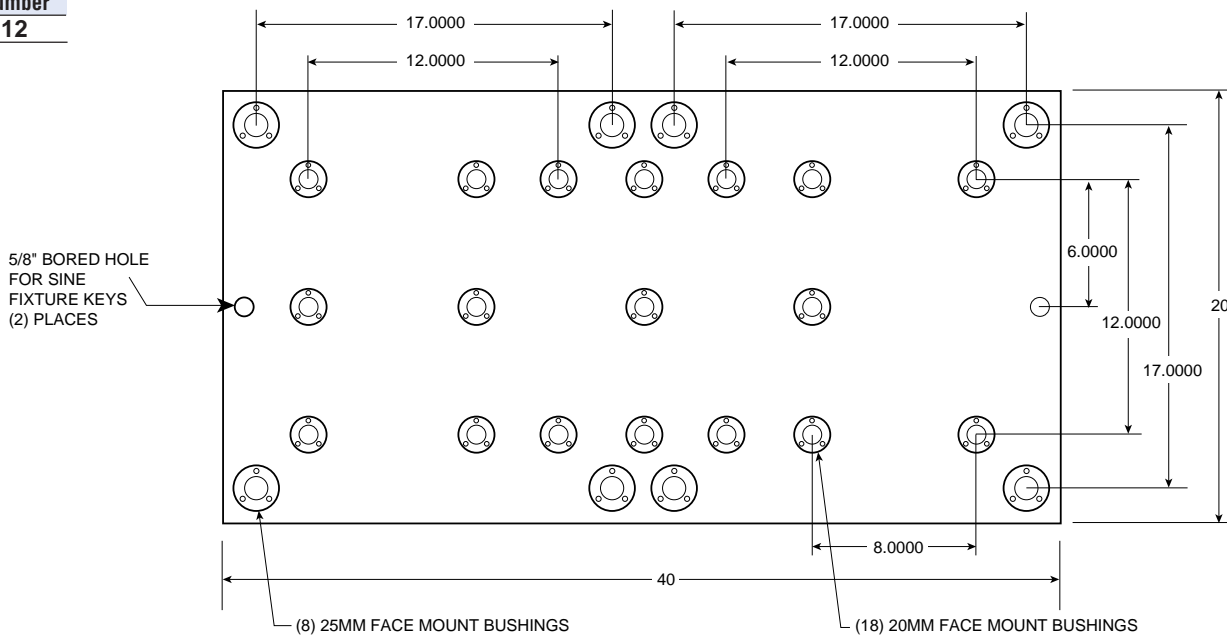

Fixture Plate Options for Multi-Purpose Subplates – Aluminum or Steel

Fixture Plate* Part Number	Thickness of Fixture Plate	Number of Fixture Plates That Mount on Multi-Purpose Subplate	Receiver Bushing Center Distance	Receiver Bushing Size	Required Ball Lock Shank Part Number	Number of Shanks Required Per Fixture Plate
28713 (14 x 14) Fixture Plate	3/4"	2	12 x 12	20 mm	49601	4
28715 (16 x 16) Fixture Plate	3/4"	2	12 x 12	20 mm	49601	4
28801 (16 x 16) Modular Grid Plate	1 1/8"***	2	12 x 12	20 mm	49602	4
28706 Jigsaw Interlocking Plate	3/4"	4	8 x 12	20 mm	49601	3
28727 (20 x 20) Fixture Plate	1"	2	17 x 17	25 mm	49612	4
28719 (20 x 16) Fixture Plate	3/4"	1	16 x 12	20 mm	49601	4

* See next page for dimensional data on fixture plates. Part numbers shown for aluminum plates, also available in steel.

** Counterbored to 1" at mounting holes.

Fixture Plates for Use on Multi-Purpose Subplate

14x14 Fixture Plate

Aluminum Plate	Steel Plate
Part Number	Part Number
28713	28813

16x16 Fixture Plate

Aluminum Plate	Steel Plate
Part Number	Part Number
28715	28815

- Material: Alca Plus Cast Aluminum or FreMax 15 Steel
- Thickness: 3/4"
- Thickness Tolerance: ±.005
- Weight (14x14): Aluminum 14 lbs., Steel 42 lbs.
- Weight (16x16): Aluminum 18 lbs., Steel 55 lbs.

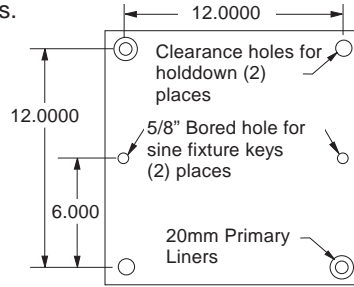

16x16 Modular Grid Fixture Plate

Steel Plate
Part Number
28801

- Material: FreMax 15 Steel
- Thickness: 1 1/8"
- Thickness Tolerance: ±.005
- Weight: 80 lbs.

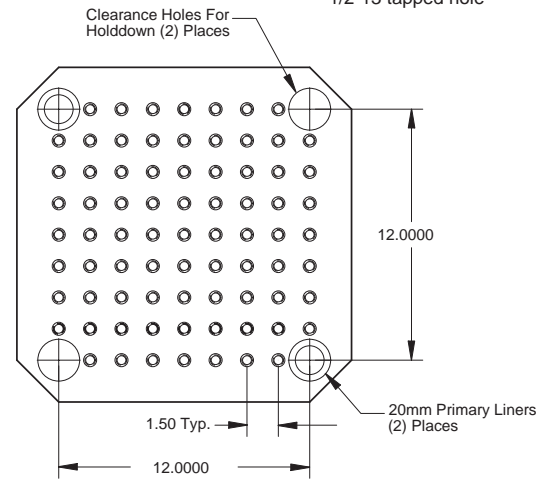
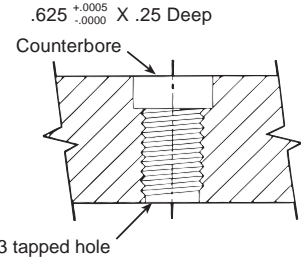

Jigsaw Interlocking Plate

Aluminum Plate Part No	Steel Plate Part No	A	B	C	D	Jergens Vise P/N
28705	-	7.97	5.97	15.00	6.0000	49401
28706	28806	9.97	7.97	16.00	8.0000	49402

- Material: Alca Plus Cast Aluminum or FreMax 15 Steel
- Thickness: 3/4"
- Thickness Tolerance: ±.005
- Weight: Aluminum 9 lbs., Steel 27 lbs.
- For use with straight base 4" or 6" vises
- Unique design minimizes center distances between vises allowing for more parts on a production run
- Easily mounts to Multi-Purpose Subplate using the Ball Lock Mounting System
- Adaptable to nesting small parts

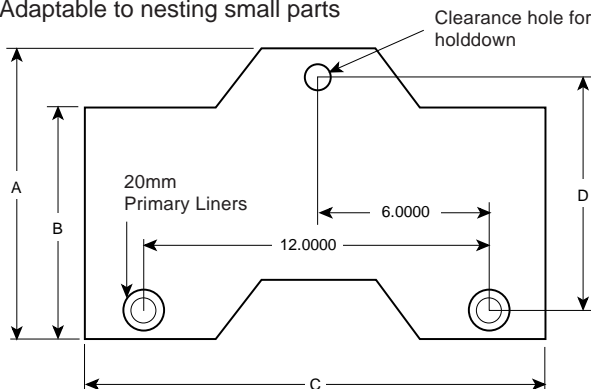

20x20 Fixture Plate

Aluminum Plate	Steel Plate
Part Number	Part Number
28727	28827

- Material: Alca Plus Cast Aluminum or FreMax 15 Steel
- Thickness: 1"
- Thickness Tolerance: ±.005
- Weight: Aluminum 38 Lbs., Steel 114 lbs.

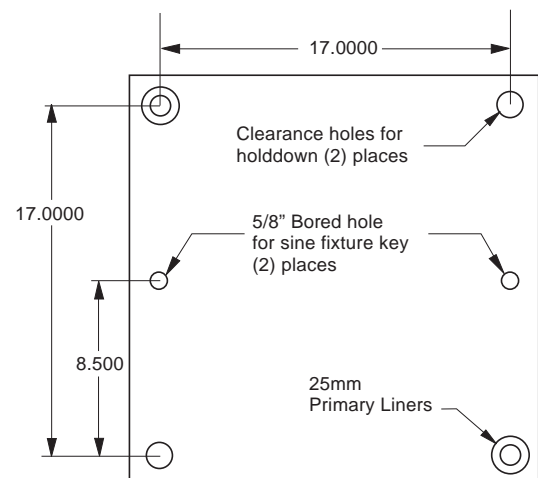

Pre-Machined Ball Lock Steel Subplates

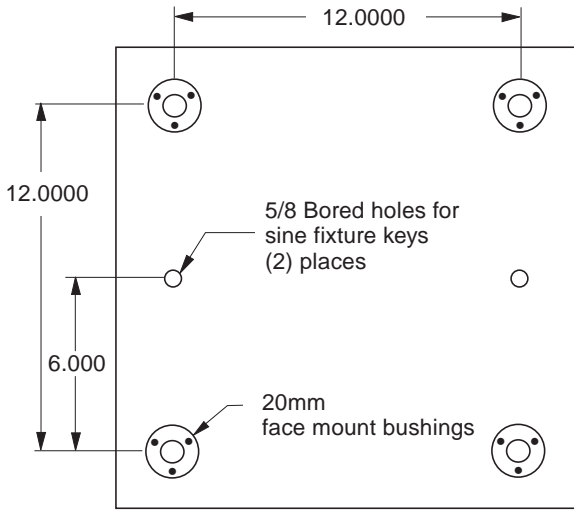

To make the job easier, the Ball Lock Quick Change Kit includes all components needed in a single package. See page 1.15 for details.

16x16 Subplate

Part Number
49101

Equipped with four 20mm receiver bushings for use with 14x14 or 16x16 fixture plates. Ideal for horizontal machining centers or multiple pallet machining centers.

- Material: Fremax™ 15 steel plate
- Flat within .001
- Thickness: 1-1/8"
- Thickness tolerance: ±.005
- Weight: 81 lbs.

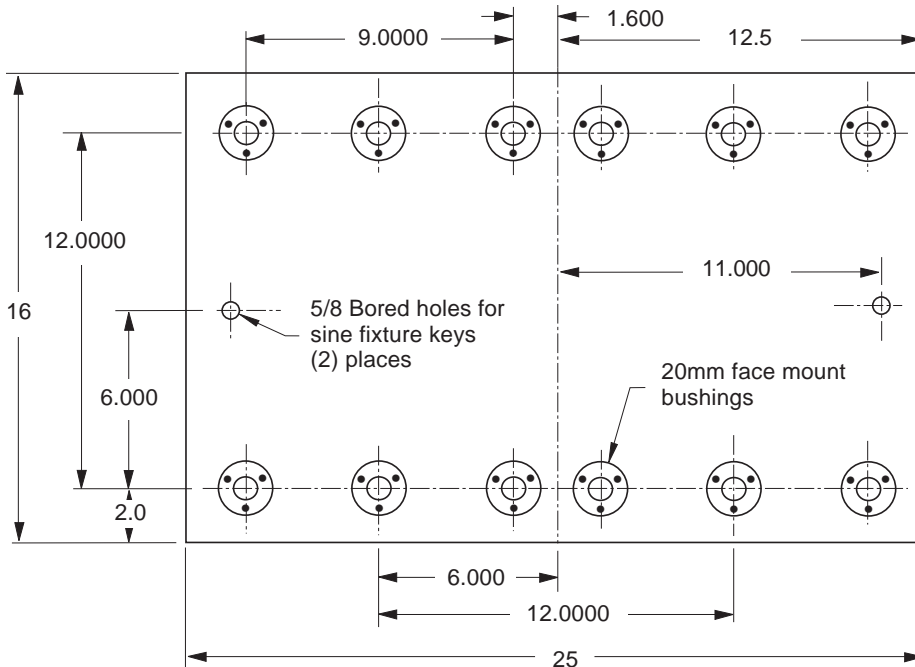

16x25 Dual Station Subplate

Part Number
49111

Equipped with twelve installed 20mm receiver bushings to easily locate and mount the following fixture plates:

Part Number	Number of Fixture Plates	Plate Width and Length
28713	1	14"x14"
28715	1	16"x16"
28711	2	12"x14"

- Ideal for vertical machining centers.
- Thickness: 1-1/8"
- Weight: 128 lbs.

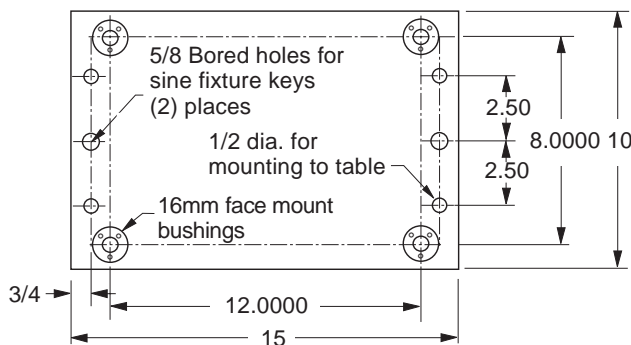

10x15 Bridgeport™ - Style Subplate

Part Number
49121

Equipped with four installed 16mm receiver bushings and 1/2" mounting holes. Used with the Bridgeport™ style fixture plate.

- Thickness: 3/4"
- Weight: 32 lbs.

Pre-Machined Ball Lock Fixture Plates

- Material: Alca Plus Cast Aluminum* or FreeMax 15 Steel
- Flat within .005
- Thickness tolerance $\pm .005$
- 6061-T-651 plates, flat within .001 available upon request

Pre-Machined Ball Lock Fixture Plates

Part Number				Plate Width and Length (in.)	Plate Thickness (in.)	Ball Lock Shank Size (mm)
Aluminum	Weight (lbs)	Steel	Weight (lbs)			
28706	9	28806	27	9.97 x 16	.75	20
28711	12	28811	36	12 x 14	.75	20
28713	14	28813	42	14 x 14	.75	20
28715	18	28815	55	16 x 16	.75	20
28722	16	28822	48	12 x 14	1.00	25
28724	19	28824	56	14 x 14	1.00	25
28726	24	28826	73	16 x 16	1.00	25
28719	23	28819	68	20 x 16	.75	20
28727	38	28827	114	20 x 20	1.00	25
28731	11	28831	32	10 x 15	.75	16
–	–	28801	80	16 x 16	1.125	20

- Pre-machined to close distance tolerance
- Ensure $\pm .0005$ " repeatability of the Ball Lock System
- Includes pre-installed primary liners
- Reduces fixture set-up and assembly time
- Provided with 5/8" reamed holes for sine fixture keys
- Ideal for horizontal or vertical machining centers, Bridgeport™ style machines, or multiple pallet machining centers

* Alca Plus is a trademark of Alcoa Aluminum Co.

Note: Each plate has two primary liners installed.

Custom Sizes Available

Jergens will make any size Ball Lock fixture plate or subplate to your specifications. Call 1-800-JERGENS for further information.

10x15 Fixture Plate Bridgeport™ Style

Aluminum Plate
Part Number
28731

Steel Plate
Part Number
28831

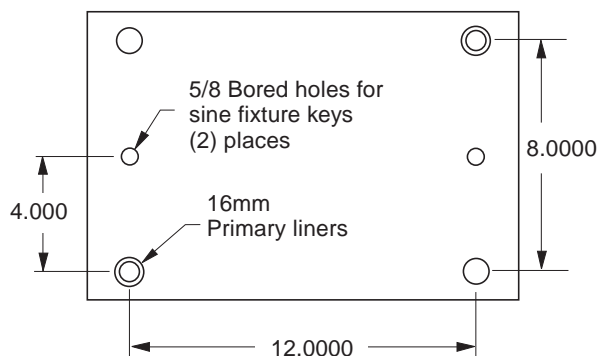

12x14 Fixture Plate

Aluminum Plate
Part Number
28711

Steel Plate
Part Number
28811

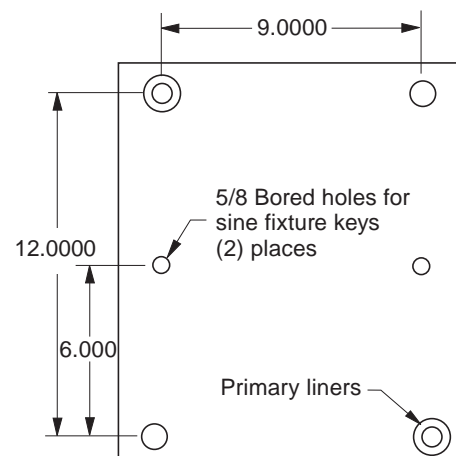

Pre-Machined Ball Lock T-Columns

- Material: Class 40 Meehanite cast iron
- Also available in Aluminum
- Ball Lock Receiver Bushings and Liners installed
- Provides accurate fixturing base for CNC machining centers
- Perpendicularity is .001 per foot

Custom Sizes Available

We are able to quote you on your special requirement columns, pre-machined with or without the Ball Lock components installed in place. Call 1-800-JERGENS for design specification information.

Cast Iron T-Columns With Ball Lock Receiver Bushings Installed

Part Number	C	D	E	F	G	H	I	J	K	L	Wt. (lbs)
69101	16.375	1	16	16	14	14	14	14	4	19.875	425
69111	22.375	1	20	20	19	17	17	17	4.7	25.875	700
69121	26.375	1.5	25	25	23	22	21	21	4	29.875	1125

Dimensions continued from above.

Part Number	M	N	O (mm)	P (mm)	Fixture Plate Part Number	Sub Plate Part Number
69101	4.875	3.5	20	20	28717	49102
69111	5.375	3.5	25	25	28745	49103
69121	5.375	3.5	35	25	28746	49104

Note: Window sections are also available on T-Columns.
Window size and location (Q and R Dimensions) to be specified by customer.

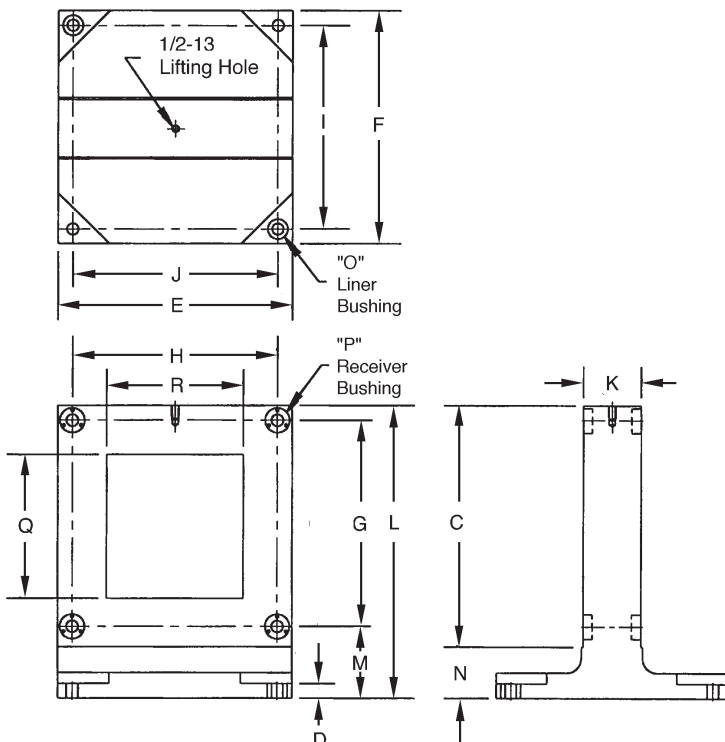

Engineering Changes

Product improvement is a continuing process at Jergens. Specifications and engineering data are subject to change without notice. If current information is critical to your design, it is suggested that you contact Jergens Technical Sales Department to verify any dimensions or specifications.

Use Hoist Ring **23411** for lifting and handling – Order separately.

Pre-Machined Ball Lock 4-Sided Tooling Columns

- Material: Class 40 Meehanite cast iron
- Also available in Aluminum
- Ball Lock Receiver Bushings and Liners installed
- Provides accurate fixturing base for CNC machining centers
- Perpendicularity is .001 per foot

Cast Iron 4-Sided Tooling Columns With Ball Lock Receiver Bushings Installed

Part Number	A	B	C	D	E	F	G	H	I	J	K	L	M	N	Wt. (lbs)
69001	10	10	20	1	16	16	18	6.75	14	14	1.75	23.875	4.875	3.875	510
69011	12	12	25	1	20	20	22	8	17	17	1.625	28.875	5.375	3.875	736
69021	16	16	26	1.5	25	25	23	11.50	21	21	2	29.875	5.375	3.875	1122

Dimensions continued from above.

Part Number	O (mm)	P (mm)	Fixture Plate Part Number	Sub Plate Part Number
69001	20	20	28741	49102
69011	25	25	28742	49103
69021	35	25	28743	49104

Custom Sizes Available

We are able to quote you on your special requirement columns, pre-machined with or without the Ball Lock components installed in place. Call 1-800-JERGENS for design specification information.

Use Hoist Ring **23411** for lifting and handling – Order separately.

Engineering Changes

Product improvement is a continuing process at Jergens. Specifications and engineering data are subject to change without notice. If current information is critical to your design, it is suggested that you contact Jergens Technical Sales Department to verify any dimensions or specifications.

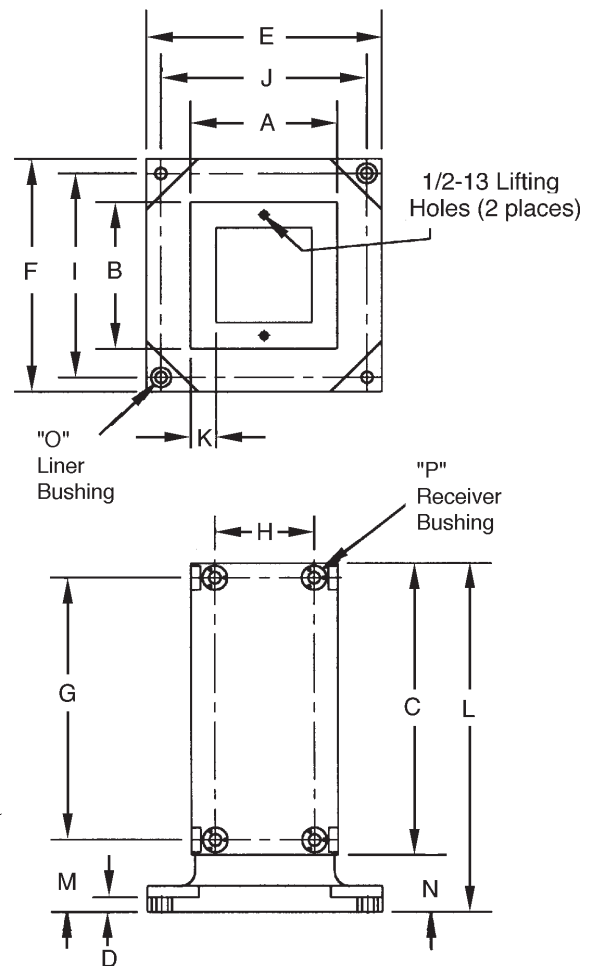

Standard Subplates and Fixture Plates for Tooling Columns

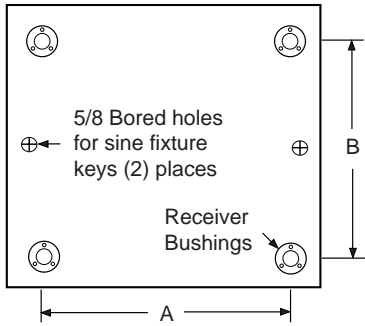

Standard Steel Subplates for Tooling Columns

Part Number	Pallet Size (mm)	For Tooling Columns	A (in.)	B (in.)	Receiver Size (mm)	Thickness of Subplate (in.)	Wt (lbs)
49102	400	69001, 69101	14	14	20	1.125	79
49103	500	69011, 69111	17	17	25	1.25	137
49104	630	69021, 69121	21	21	35	1.375	240

Note: Mounting holes can be provided per customer specification. Supplied with Ball Lock Receiver Bushings installed.

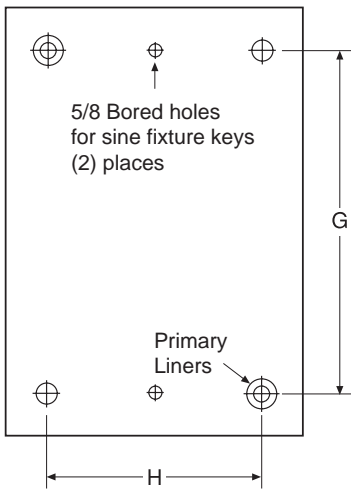

Fixture Plates for Standard Tooling Columns and T-Columns

Part Number				For Tooling Columns	Fixture Plate Size (in.)	H (In.)	G (In.)	Liner Size (mm)	Fixture Plate Thickness (in.)
Aluminum	(lbs)	Steel	(lbs)						
28741	14	28841	43	69001	10x20	6.75	18	20	.75
28742	28	28842	86	69011	12x25	8	22	25	1
28743	39	28843	119	69021	16x26	11.50	23	25	1
28717	18	28817	55	69101	16x16	14	14	20	.75
28745	41	28845	125	69111	20x22	17	19	25	1
28746	61	28846	186	69121	25x26	22	23	25	1

Supplied with Ball Lock Liner Bushings installed.

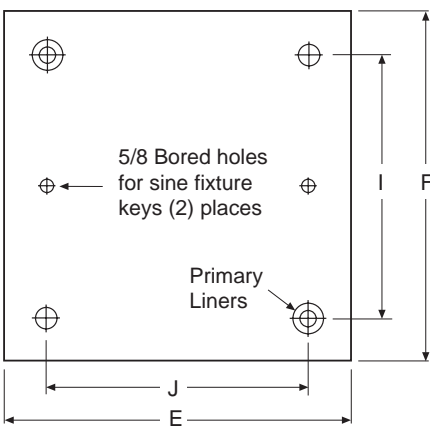

Fixture Plates for Tooling Column Subplates

Part Number				For Subplate	E (In.)	F (In.)	I (In.)	J (In.)	Liner Size (mm)	Fixture Plate Thickness (in.)
Aluminum	(lbs)	Steel	(lbs)							
28717	18	28817	55	49102	16	16	14	14	20	.75
28727	38	28827	114	49103	20	20	17	17	25	1
28732	58	28832	177	49104	25	25	21	21	35	1

Supplied with Ball Lock Liner Bushings installed.

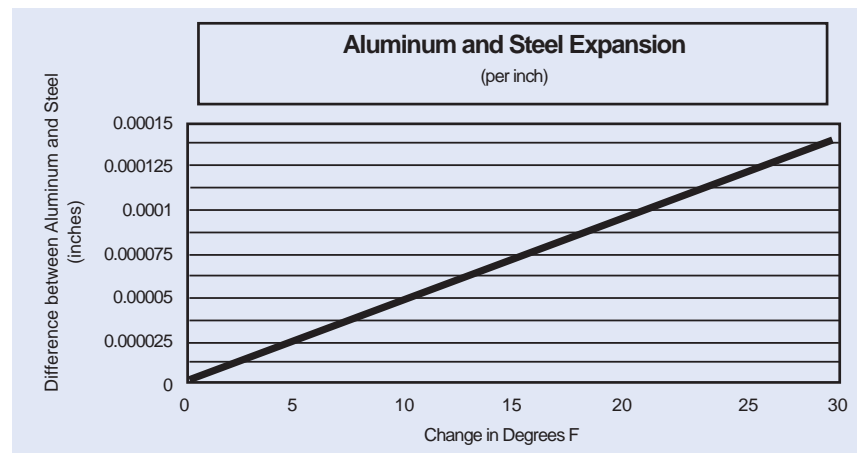

NOTE: Aluminum and steel expand at different rates. Please take this information into consideration when creating your own Ball Lock fixture and subplates.

Quick Change Kits

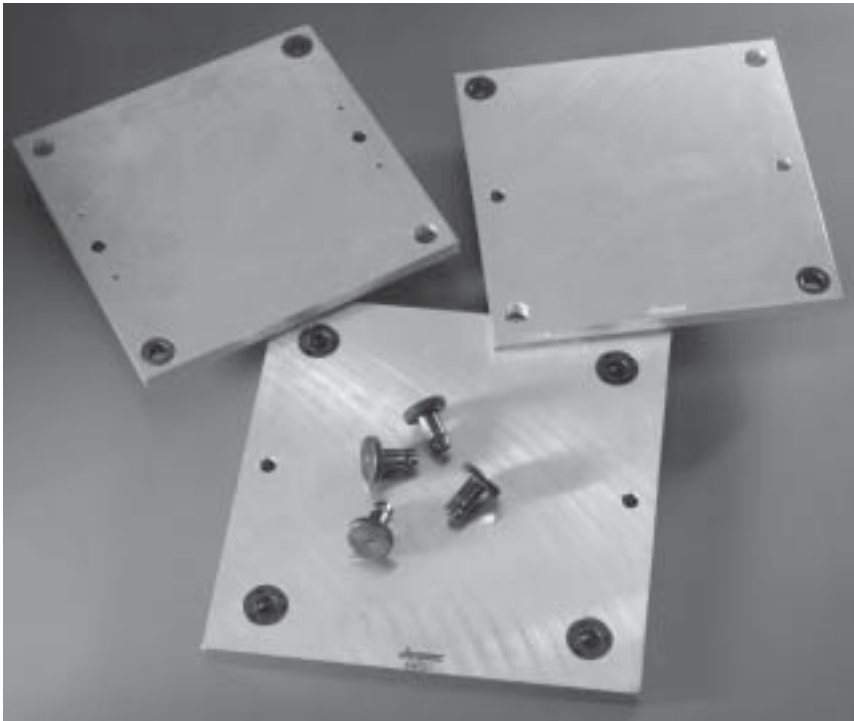

Everything You Need to Change Fixtures in Less Than One Minute

The Jergens Ball Lock™ Quick Change Kits speed fixture changeover in all types of manufacturing operations. Each kit includes two aluminum fixture plates with liner bushings installed; one steel subplate with receiver bushings installed; and four 20mm Ball Lock shanks with working loads of 3000 lbs. each. While one fixture plate is on the machine, the operator can load parts on the other. This minimizes downtime for true set-up reduction. To enable the subplate to be mounted on a slotted table without the need to indicate the subplate, sine fixture keys can be used. The sine fixture key reamed holes are oriented parallel to the receiver bushings on the subplate and to the liner bushings on the fixture plate. These also allow the fixture plate to be mounted on a toolroom mill without the need to indicate it. This is extremely useful when machining location points on your fixture.

Aluminum Fixture Plate

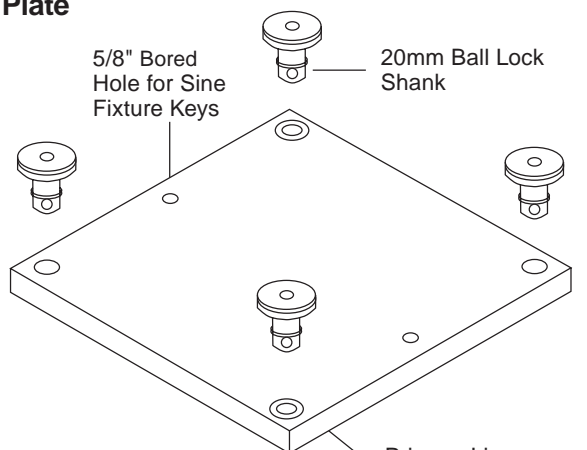

Steel Subplate

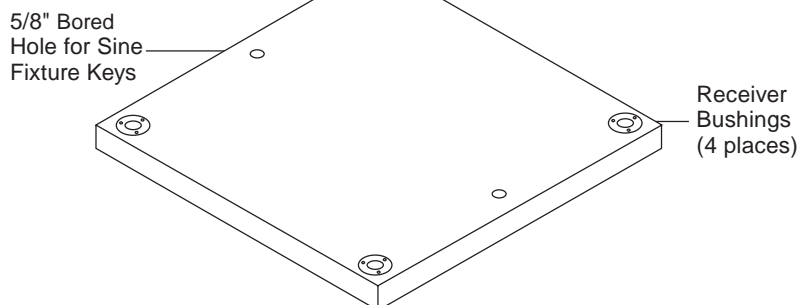

Quick Change Kits

Part No.	Kit Includes
49001	2 - 3/4" x 14" x 14" aluminum fixture plates with 20mm liner bushings installed 1 - 1-1/8" x 16" x 16" steel subplate with receiver bushings installed 4 - 20mm Ball Lock Shanks
49002	2 - 3/4" x 16" x 16" aluminum fixture plates with 20mm liner bushings installed 1 - 1-1/8" x 16" x 16" steel subplate with receiver bushings installed 4 - 20mm Ball Lock Shanks
49004	Bridgeport™-Style 2- 3/4" x 10" x 15" aluminum fixture plates with 16mm liner bushings installed 1- 3/4" x 10" x 15" steel subplate with receiver bushings installed 4- 16mm Ball Lock Shanks

Pre-Engineered Ball-Lock™ Fixture Kits for HAAS*

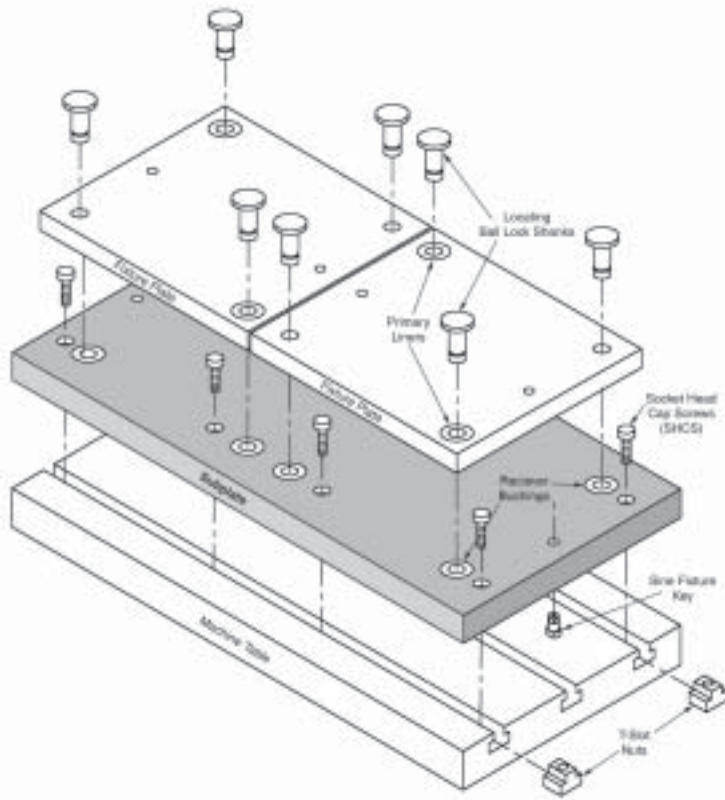

These kits include:

- Steel Subplate
- Aluminum Fixture Plate(s)
- Pre installed receiver and Liner Bushings
- Ball-Lock Shanks
- T-Slot nuts for mounting subplate to machine table
- 2 Sine Fixture Keys for accurate subplate locating
- Socket head cap screws

Benefits:

- Save time specifying and ordering
- Saves installation time and cost
- Eliminates potential installation errors



Jergens Kit Number	Fix. Plates	Jigsaw Plates	HAAS Model Number
50000	1	—	MINI-MILL
50001	1	—	
50002	2	—	VF-E, VF-O, VF-1
50003	2	—	
50004	—	2	
50005	2	—	
50006	—	3	VF-OE, VF-2
50007	2	—	
50008	—	3	VF-3
50009	2	—	
50010	3	—	
50011	—	5	
50012	2	—	
50013	2	—	
50014	2	—	
50015	2	—	
50016	—	5	

Jergens Kit Number	Fix. Plates	Jigsaw Plates	HAAS Model Number
50017	3	—	VF-4
50018	4	—	
50019	—	6	
50020	2	—	
50021	2	—	
50022	2	—	
50023	2	—	
50024	3	—	
50025	3	—	
50026	—	6	
50027	—	6	
50028	2	—	VF-5
50029	2	—	
50030	3	—	
50031	—	6	
50032	2	—	
50033	2	—	
50034	3	—	
50035	3	—	
50036	—	6	

Ask about other manufacturers available.

Ask about other manufacturers available.

Call customer support services at 1-800-537-4367 or see Jergens Ball Lock kits for HAAS* catalog for additional information.

*HAAS is a trademark of HAAS Automation Inc.

Ball Lock™ For Rotary Indexers

Problem:

Although your rotary indexer increases the versatility of a vertical machining center, it has one major limitation: set-up is so laborious and time-consuming that it limits the machine's flexibility. In many cases, folks dedicate their units to a single machine tool to avoid the agony of an extended set-up and changeover.

Subplates and fixture plates come with bushings pre-installed.

Benefits:

- Maximize indexer utilization
- Eliminate lengthy set-ups
- Accurate fixture plate changeover in seconds

Jergens' Solution:

Our new Ball Lock Mounting System for Indexers provides a two-pronged solution.

First, Ball Lock mounting plates free up your machine tool for additional work by allowing a fast and accurate quick change of the complete indexer. No longer will you spend hours doing set up. The Ball Lock System does it in minutes, with repeatability at $\pm .0005"$ ($\pm .013\text{mm}$). Low profile, positive clamping, proven in over ten years of field use.

Second, the Ball Lock System puts your fixture plate changeovers into high gear. By mounting the round subplate to the indexer faceplate, you'll "plug-in" new fixtures in record time (less than 60 seconds).

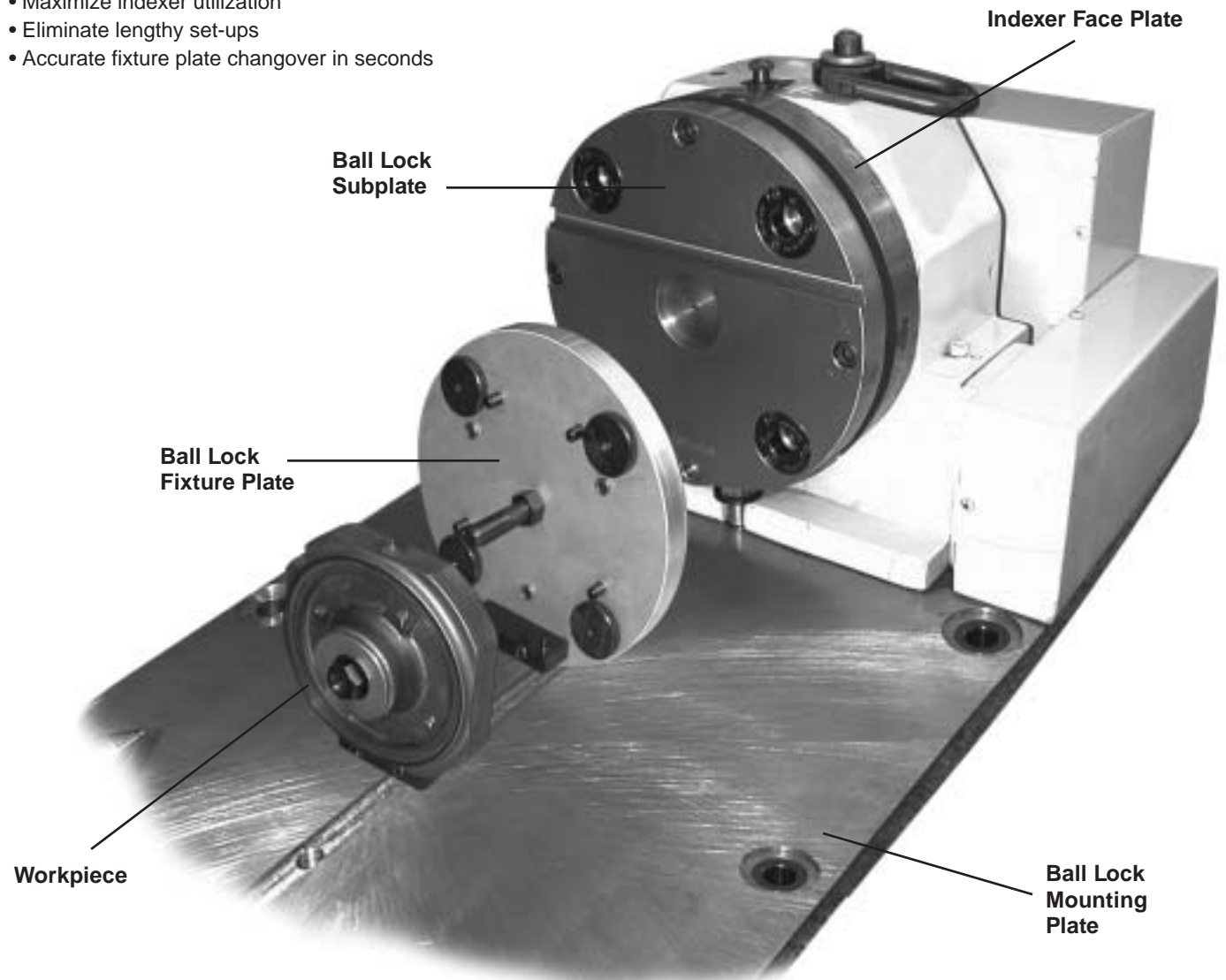

Building a System

Standard Systems

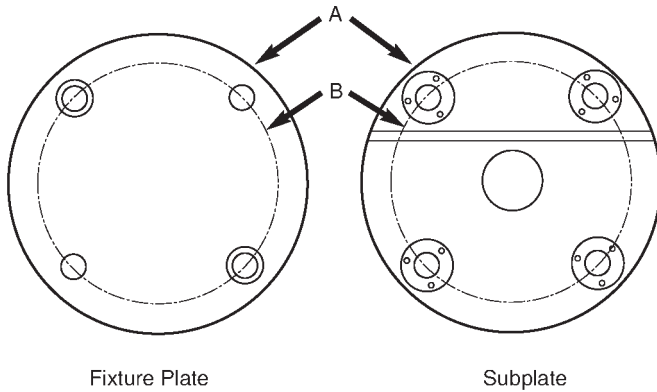

Fixture Plate

Subplate

Custom Systems

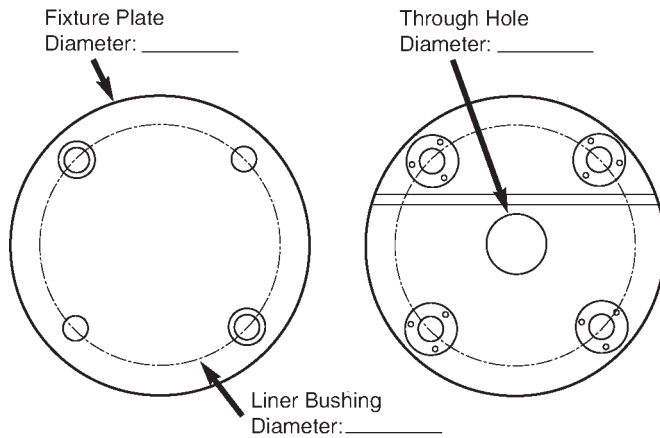

Fixture Plate Diameter: _____

Through Hole Diameter: _____

Liner Bushing Diameter: _____

Indexer:

Make: _____

Model: _____

Diameter: _____

Light Duty or Heavy Duty: _____

Through Hole Bore: _____

Machine It Is Going On:

Make: _____

Model: _____

Weight Capacity: _____

Indexer Faceplate:

T-Slot Size: _____

Configuration/Orientation: _____

or

Drilled Tapped Hole Size:

Configuration/Orientation: _____

Material:

- Fixture Plate: Alca Plus™ cast aluminum, ±.005 thickness tolerance
- Subplate: Fremax™ 15 steel, ±.005 thickness tolerance

Fixture Plate

Part No.	A	B	Thickness	Ball Lock Liner	Ball Lock Shank	Weight
28707	8"	6"	0.75"	16mm	49608	3.5 lbs.
28708	10"	8"	1.00"	20mm	49602	7.0 lbs.
28709	12"	10"	1.00"	20mm	49602	11.0 lbs.

Subplate

Part No.	A	B	Thickness	Ball Lock Receiver	Center Hole	Weight
49107	8"	6"	0.75"	16mm	1.00"	11.0 lbs.
49108	10"	8"	1.00"	20mm	2.00"	21.0 lbs.
49109	12"	10"	1.00"	20mm	2.00"	33.0 lbs.

Metric sizes also available; please call for information.

Engineering Changes

Product improvement is a continuing process at Jergens. Specifications and engineering data are subject to change without notice. If current information is critical to your design, it is suggested that you contact Jergens Technical Sales Department to verify any dimensions or specifications.

Accessories

Tapered Caps and Plugs

Keep debris out of your subplate's receiver bushings when they are not in use. Polyethylene caps easily snap in and out.



Packaged 10 per pack.

Receiver Bushing Diameter	Part Number
13	49201
16	49202
20	49203
25	49204
30	49205
35	49206
50	49207

Adjustable Handles

For easy engagement and disengagement of 16mm through 35mm Ball Lock™ shanks. Handle moves out of the way of the machine operator. To install: remove existing set screw on shank and replace with handle.



Part Number	Plate Thickness	Shank Diam
34315	1/2 3/4	16mm 20mm
34316	1	20mm
34328	3/4	25mm
34329	1	25mm
34334	3/4	30mm
34335	1	30mm
34339	3/4 1	35mm 35mm



Lifting Handles

For easy handling of fixture plate.

Part Number
33701

Sine Fixture Keys



Locate subplates or fixture plates to slotted machine tables without having to slot the plate. Available in inch sizes from 1/2" to 7/8" slots, and in metric sizes from 14mm to 22mm slots.
NOTE: See master catalog for additional dimensions.

Part Number	Table Slot Size	Part Number	Table Slot Size (mm)
39501	1/2	39562	14
39502	9/16	39563	16
39503	5/8	39564	18
39504	11/16	39565	20
39505	3/4	39566	22
39506	13/16		
39507	7/8		

NOTE: All shanks are 5/8" diameter

Fast Acting Ball Lock™ Shanks

Ball Lock Shank Diameter (mm)	Fixture Plate Thickness (in.)	FAST ACTING			
		Jergens Ball Lock Shank w/Jergens Thumb Screw		Jergens Ball Lock Shank w/Elesa Adjustable Handle	
		Part Number		Part Number	
		Assembly	T-Screw	Assembly	Handle
16	1/2	49607-S	43904	49607-H	34314
	3/4	49608-S	43904	49608-H	34315
20	3/4	49601-S	43904	49601-H	34315
	1	49602-S	43905	49602-H	34316
25	3/4	49611-S	43907	49611-H	34328
	1	49612-S	43908	49612-H	34329
30	3/4	49621-S	43910	49621-H	34334
	1	49622-S	43911	49622-H	34335
35	3/4	49631-S	43913	49631-H	34339
	1	49632-S	43913	49632-H	34339
	1-1/2	49633-S	43914	N/A	
	2	49634-S	43914	N/A	



Thumb Screw



Adjustable Handle

Lite Lock™ Mounting System

Light Duty Mounting System Locates and Locks One Plate to Another

The Jergens Lite Lock Mounting System is a cost-effective method of eliminating downtime and reducing the changeover cycle in the production process. With only one moving part, changing assembly fixtures, fixture plates, or any process involving mounting one plate on top of another, becomes a simple and quick operation.

The Lite Lock Mounting System, like the heavier duty Jergens Ball Lock™ Mounting System, locates and locks two plates together accurately and quickly. By simply pushing the release button located on the Lite Lock cartridge, an operator can change the top plate, loaded with parts, in a matter of seconds!

This quick release concept is adaptable to a wide range of applications and machinery. It eliminates the need for conventional fasteners such as bolts and screws.

The Lite Lock Mounting System is available as a complete assembly or as individual components for installation on your existing plates. Several sizes of top and receiver plates are available. The accurate repeatability and rugged design is ideal for the following applications:

- Product assembly
- Part transfers
- Fusion welding
- Electronic assembly
- Laser machining
- Light machining
- Circuit board drilling
- Laser etching
- Product finishing

Plate Specifications:

- Plate Material: 6061 T651 Aluminum
- Plate Thickness: 1/2", ±.003
- Plate Flatness: Flat and Parallel within ±.002
- Plate Width and Length: ±.003
- Repetitive Accuracy: ±.003

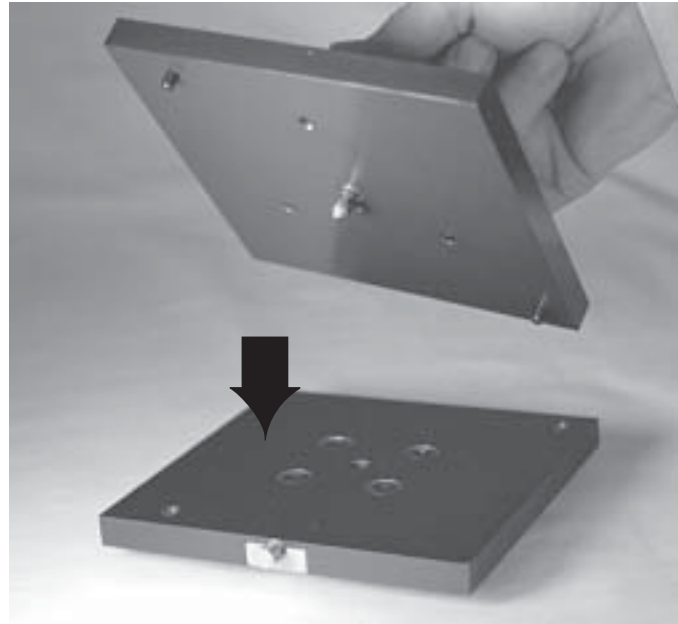

U.S. Patent No. 5,588,862

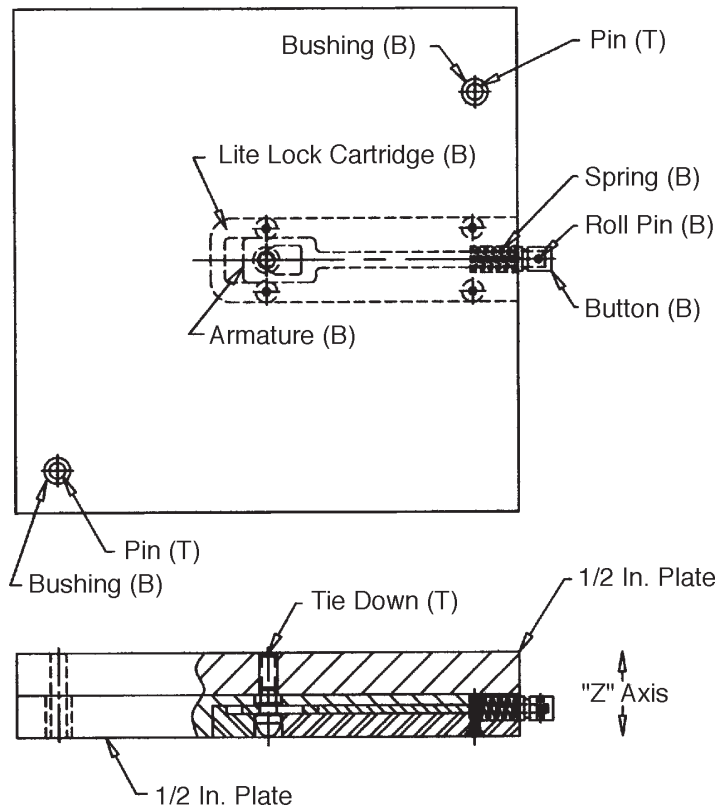

(T) Components in top actuating plate hardware kit
(B) Components in bottom plate hardware kit

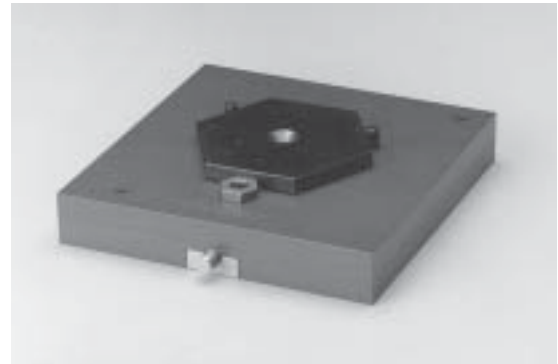
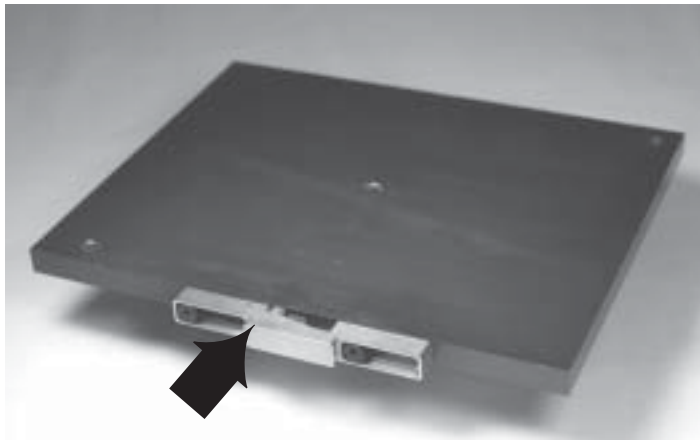

Slide Lock Mechanism standard on 8"x10" and 12"x12" Receiver Plates.
Available as option for smaller plates. Order Part Number 49303.

Complete Assembly

Plate Size	Top and Receiver Plate Assembled Part Number
6" x 6" x 1/2"	49341
6" x 8" x 1/2"	49342
8" x 10" x 1/2"	49343
12" x 12" x 1/2"	49344

Top Plate Assembly

(includes installed hardware)

Plate Size	Top Plate Part Number
6" x 6" x 1/2"	49336
6" x 8" x 1/2"	49337
8" x 10" x 1/2"	49338
12" x 12" x 1/2"	49339

Receiver Plate Assembly

(includes installed hardware)

Plate Size	Receiver Plate Part Number
6" x 6" x 1/2"	49331
6" x 8" x 1/2"	49332*
8" x 10" x 1/2"	49333*
12" x 12" x 1/2"	49334

*Lite Lock Cartridge side-mounted on rectangular plates.

Kits

Top Plate Hardware Kit

(includes tie down pin and two dowel pins)

Part Number	49302
-------------	-------

Receiver Plate Hardware Kit

(includes two bushings and an assembled cartridge)

Part Number	49301
-------------	-------

Length of adjusting rod can be modified to size.

Blank Plates

Plate Size	Part Number
6" x 6" x 1/2"	49321
6" x 8" x 1/2"	49322
8" x 10" x 1/2"	49323
12" x 12" x 1/2"	49324

Special Orders

Call us with your special requirements for any product shown in the Ball Lock Mounting System section:

- Pre-Machined Ball Lock Fixture Plates
- Subplates
- Pre-Machined Tooling Columns
- Lite Lock™ Assemblies and Components

Set-Up Reduction Worksheet

Benefits of Set-Up Reduction (Capacity)

Current Method		Example (actual case study):
Minutes per set-up	= _____ minutes	60 minutes
Number of set-ups per 8 hour shift	= _____ set-ups	1.5 set-ups
Total minutes of set-up per shift (set-up minutes x number of set-ups)	= _____ minutes	90 minutes

Using the Ball Lock System		
Minutes per set-up	= _____ minutes	8 minutes
Number of set-ups per 8 hour shift	= _____ set-ups	1.5 set-ups
Total minutes of set-up per shift (set-up minutes x number of set-ups)	= _____ minutes	12 minutes
Increased capacity per machine per shift (current method - Ball Lock method)	= _____ minutes	78 minutes
Savings per machine per shift	= _____ minutes	78 minutes
Increased capacity (number of minutes / 60)	= _____ hours	1.3 hours

Benefits of Set-Up Reduction (Profit)		
Machine cost per hour	= \$ _____	\$80.00
Increased production hours per shift (increased capacity from above)	= _____ hours	1.3 hours
Savings (profit) per machine per shift (machine cost per hour x increased production hours)	= \$ _____	\$104.00

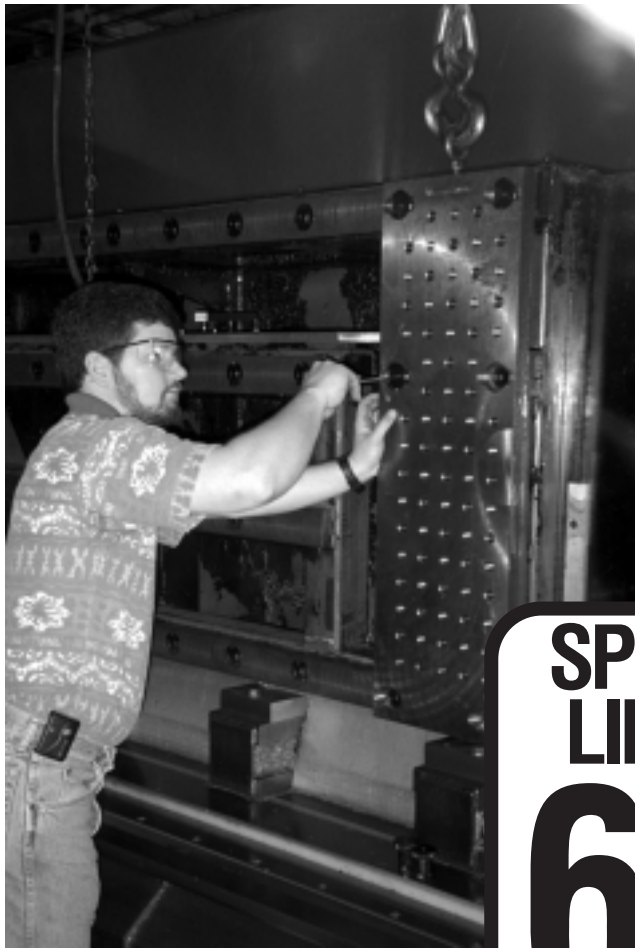

**Grid Plate Installation
Made Easy With Ball Lock**



**Fabricated Ball Lock
Tooling Column Adaptable
to Numerous Fixtures**

**SPEED
LIMIT
60
SECONDS
PER
FIXTURE
CHANGE™**

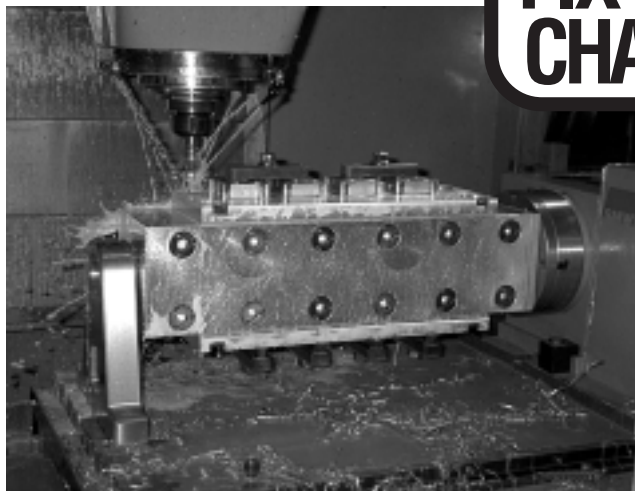

**SMW Indexer With Horizontal
Ball Lock Column**

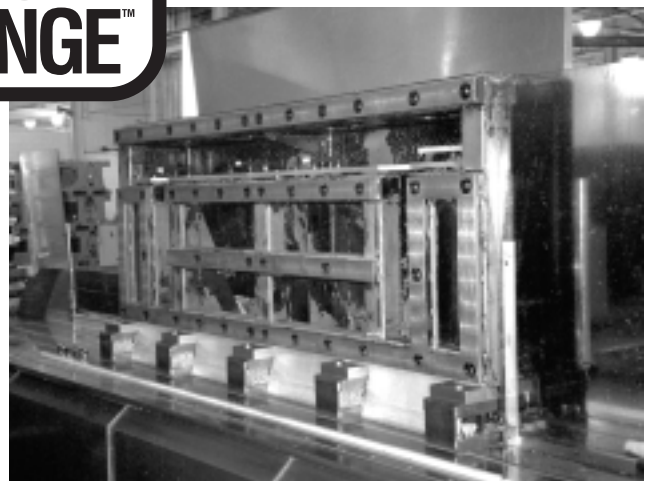

**Ball Lock Angle Fixture for
Larger Applications**

Other Catalogs Available from Jergens, Inc.

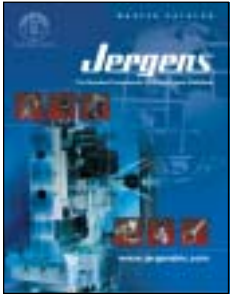

Master Catalog – Print

Over 400 pages of productivity improving products from Jergens, Inc. Including: Quick-Change Fixturing Systems, Power Clamping Systems, Fixturing Components, Machine Elements, Specialty Fasteners, Lifting Components, Toggle Clamps, Turning Tooling, and Drill Bushings.



Production Vise Catalog

Jergens offers a wide range of 4" and 6" production vises for both vertical and horizontal machining applications. Jergens vises have some unique benefits including fully machineable jaws, fully sealed lead screws and some models include an integral Ball Lock base. Production vise columns are available for 2, 4, 6, 8, 12 and 16 station applications.



Hoist Rings

For lifting strength at any angle!
Center-pull and side-pull styles are available in inch and metric sizes.
Load capacities to 50,000 lbs.
Over 100 sizes available.



Kwik-Lok™ Pins

The Jergens line of Kwik-Lok™ Pins offers a wide range of inch and metric sizes in 5 different handle styles. The pins are precision machined out of carbon steel or stainless steel, and special sizes are available with quick turnaround. Rings and lanyards are also available for easy pin attachment.



Interactive Web Catalog

The complete Jergens product line, on-line.
Always current; including the latest additions of productivity improving components and systems.
Downloadable CAD drawings and solid models of most items. Find the Jergens authorized distributor near you. Check list price and stock availability.



Jergens Way • 15700 S. Waterloo Road • Cleveland, OH 44110-3898
800-537-4367 • 216-486-5540 • Fax 216-481-6193
E-Mail: info@jergensinc.com • www.jergensinc.com